

Prof. Dr.-Ing. Stefan Deßloch  
AG Heterogene Informationssysteme  
Geb. 36, Raum 329  
Tel. 0631/205 3275  
dessloch@informatik.uni-kl.de



# Overview



Recent Developments for Data Models

# DBMS Tasks – Historic Development

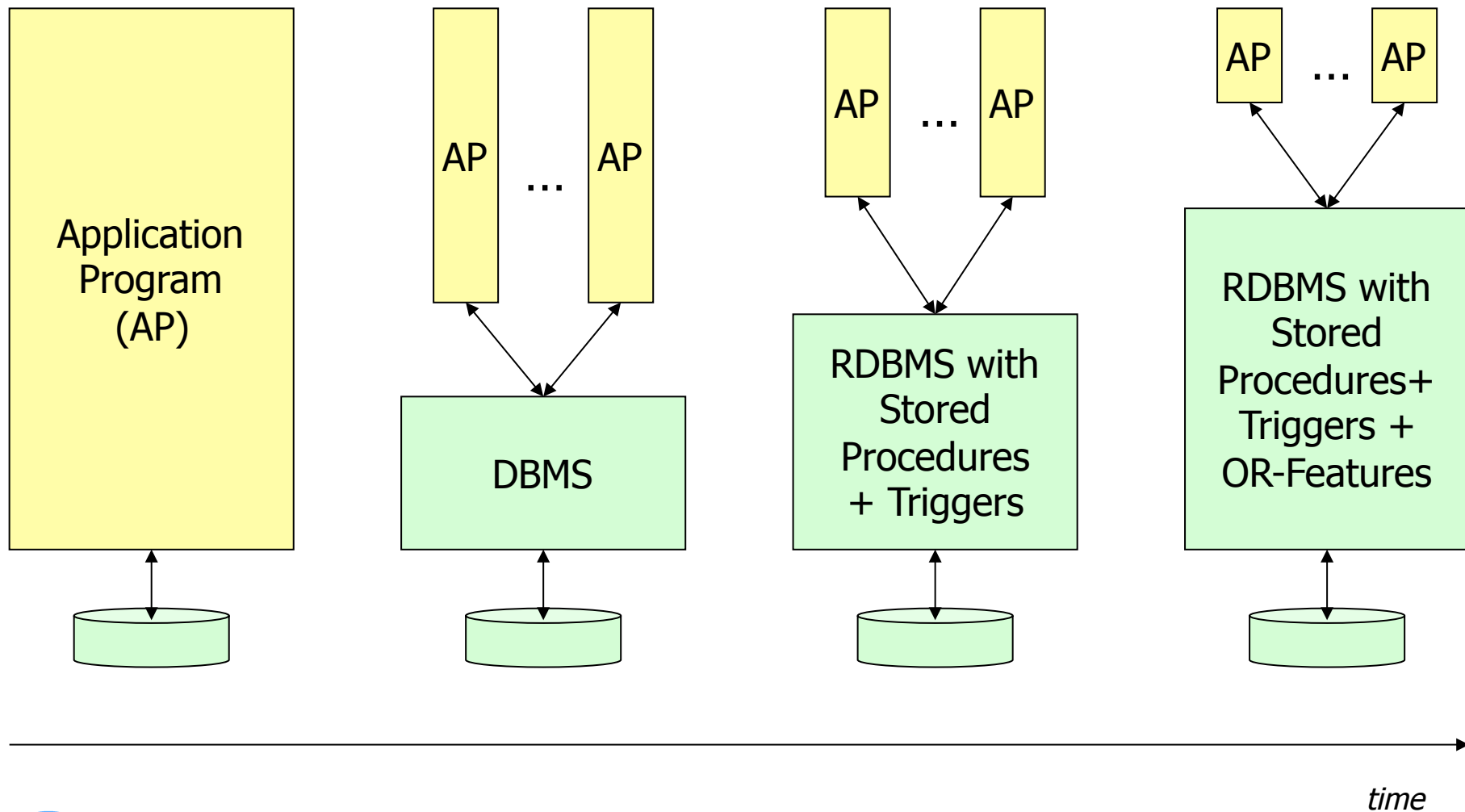

# Major Extensions in SQL:1999 and 2003

---

- Mechanism for "users" to extend the database with application "objects" (specific types and their behavior - functions/methods)
  - User Defined Types (UDTs): Text, Image, CAD/CAM Drawing, Video ...
  - User Defined Functions (UDFs): Contains, Display, Rotate, Play, ...
- Support for storage/manipulation of large data types
  - Large Object Support (LOBs): Binary, Character
- Mechanism to improve the DB integrity and to allow checking of business rules inside the DBMS
  - Triggers: Auditing, Cross-Referencing, Alerts ...
- Means to express complex data relationships such as hierarchies, bills-of-material, travel planning ...
  - Recursion, Common Table Expressions, ...
- Support for data analysis, online analytic processing
  - CUBE, ROLLUP, SQL Windows, ...
- XML support
  - XML data type, publishing functions, mapping, ...

# Object-Relational Support

---

- Major goals
  - support management of complex business objects
  - provide extensibility for defining new, complex data types and behavior
- Key features
  - Large Objects (LOBs)
    - Binary, Character
  - User-Defined Data Types
    - Distinct types, Structured types
  - Type Constructors
    - Row types, Reference types
  - Collection Types
    - Arrays, Multisets
  - User-Defined Methods, Functions, and Procedures
  - Typed tables and views
    - Table hierarchies, View hierarchies (object views)



# The "Big Picture"

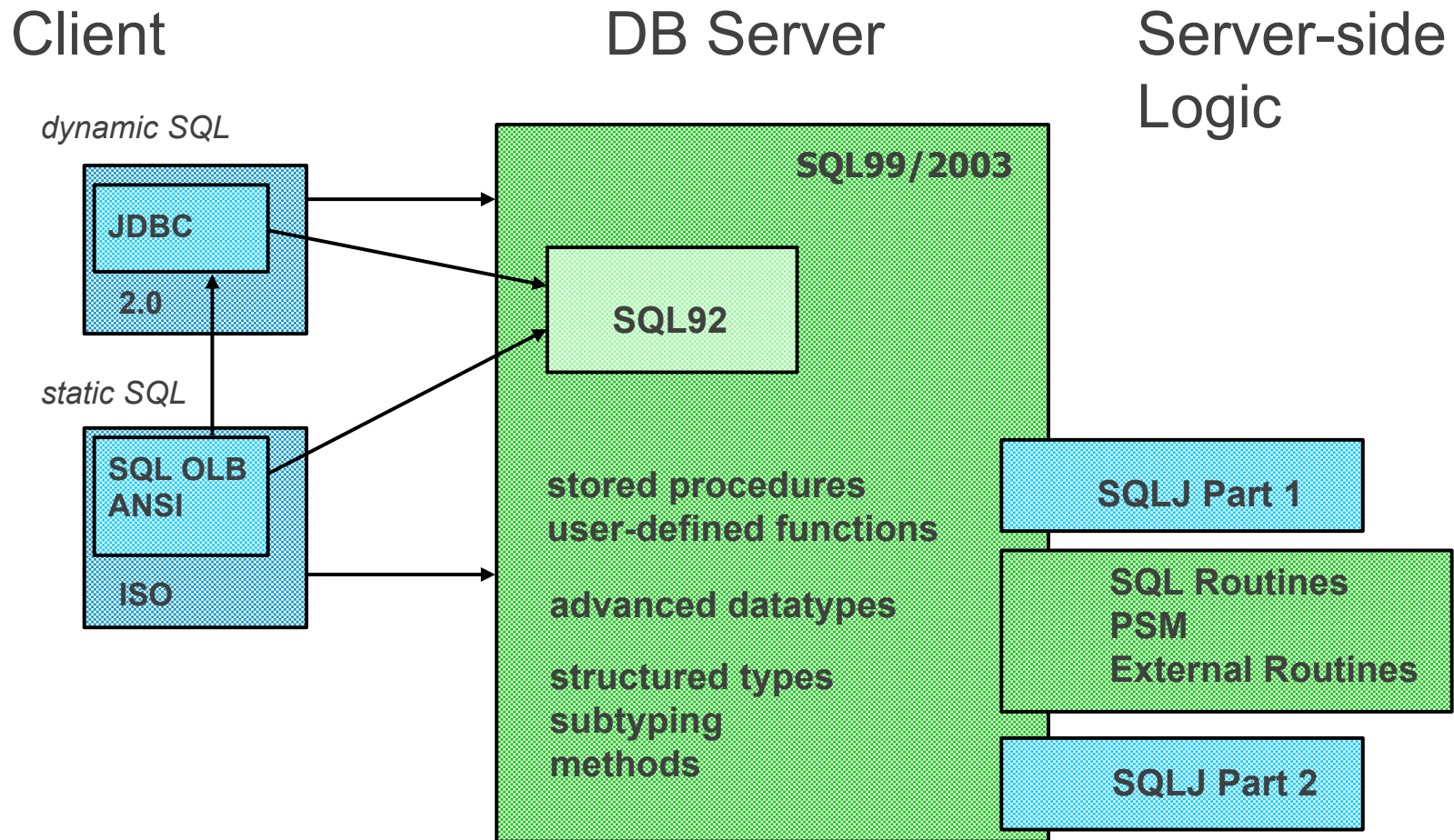

# Subtyping and Inheritance

- Structured types can be a subtype of another UDT
- UDTs inherit structure (attributes) and behavior (methods) from their supertypes
- Example
  - CREATE TYPE real\_estate ... NOT FINAL
  - CREATE TYPE apartment UNDER real\_estate ... NOT FINAL
  - CREATE TYPE house UNDER real\_estate ... NOT FINAL

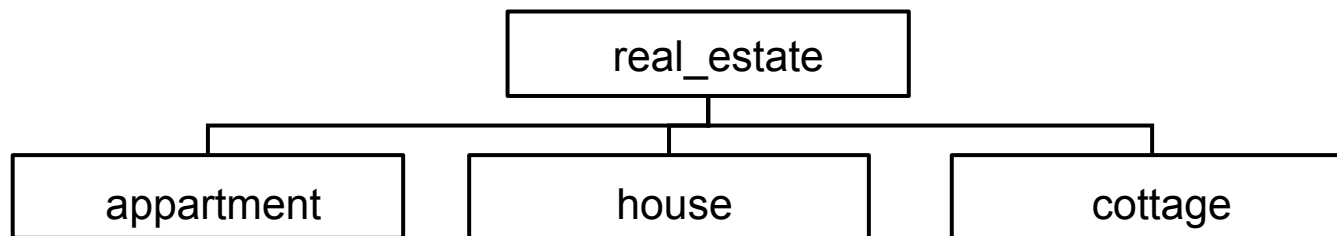

# Structured Types – Nesting and Behavior

```
CREATE TYPE envelope (
  xmin    INTEGER,
  ymin    INTEGER,
  xmax    INTEGER,
  ymax    INTEGER);
```

```
CREATE TYPE geometry (
  gtype    INTEGER,
  refsystem INTEGER,
  tolerance FLOAT,
  area     FLOAT,
  length   FLOAT,
  mbr      envelope,
  numparts INTEGER,
  numpoints INTEGER,
  points   BLOB(1m),
  zvalue   BLOB(500k),
  measure  BLOB(500k));
```

```
CREATE TYPE point UNDER geometry;
CREATE TYPE line  UNDER geometry;
CREATE TYPE polygon UNDER geometry;
```

```
CREATE FUNCTION distance
(s1 geometry, s2 geometry)
RETURNS BOOLEAN
EXTERNAL NAME
'/usr/lpp/db2se/gis!shapedist'
...
```

```
CREATE FUNCTION within
(s1 geometry, s2 geometry)
RETURNS BOOLEAN
EXTERNAL NAME
'/usr/lpp/db2se/gis!shapewithin'
...
```



# Structured Types as Column Types

---

```
CREATE TABLE customers (  
  cid      INTEGER,  
  name     VARCHAR(20),  
  income   INTEGER,  
  addr     CHAR(20)  
  loc      point);
```

```
CREATE TABLE stores (  
  sid      INTEGER,  
  name     VARCHAR(20),  
  addr     CHAR(20),  
  loc      point,  
  zone     polygon);
```

```
CREATE TABLE sales (  
  sid      INTEGER,  
  cid      INTEGER,  
  amount   INTEGER);
```





# Structured Types as Column Types

```
SELECT * FROM stores s, customers c
WHERE within(c.loc, s.zone)=1
      or distance(c.loc, s.loc)<100
ORDER BY s.name, c.name;
```

CUSTOMERS

CID	NAME	INCOME	ADDR	LOC

STORES

SID	NAME	ADDR	LOC	ZONE

"Tell me all the information I have about each customer who either lives within a stores' zone or within 100 miles of the store."

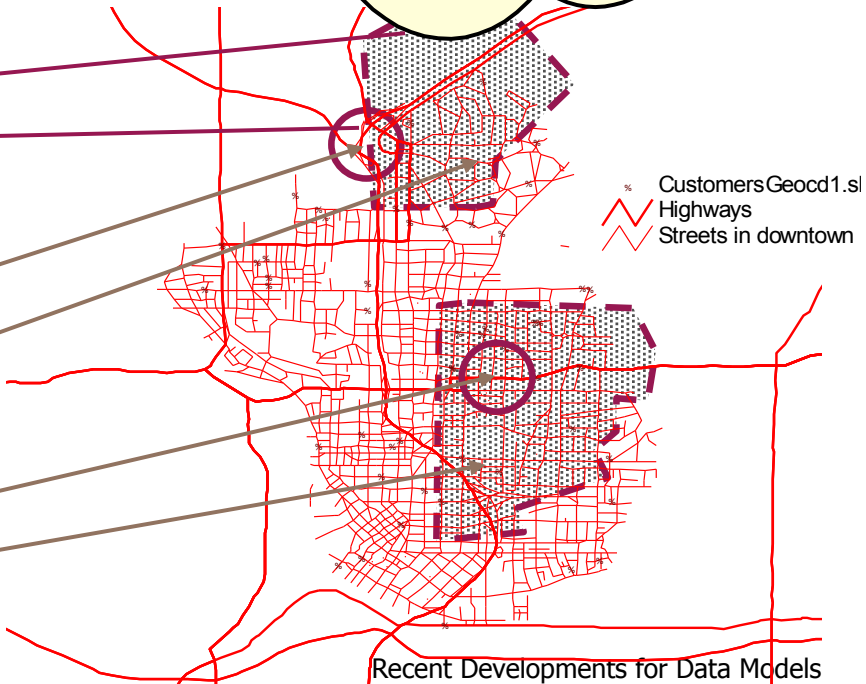

# Structured Types as Row Types: Typed Tables

---

- Structured types can be used to define typed tables
  - Attributes of type become columns of table
  - Plus one column to define REF value for the row (object id)

```
CREATE TYPE real_estate AS
(owner                REF (person),
price                money,
rooms                INTEGER,
size                 DECIMAL(8,2),
location              address,
text_description      text,
front_view_image      bitmap,
document              doc) NOT FINAL
```

```
CREATE TABLE properties OF real_estate
(REF IS oid USER GENERATED)
```



# Subtables: Table Hierarchies

---

- Typed tables can have subtables
  - Inherit columns, constraints, triggers, ... from the supertable

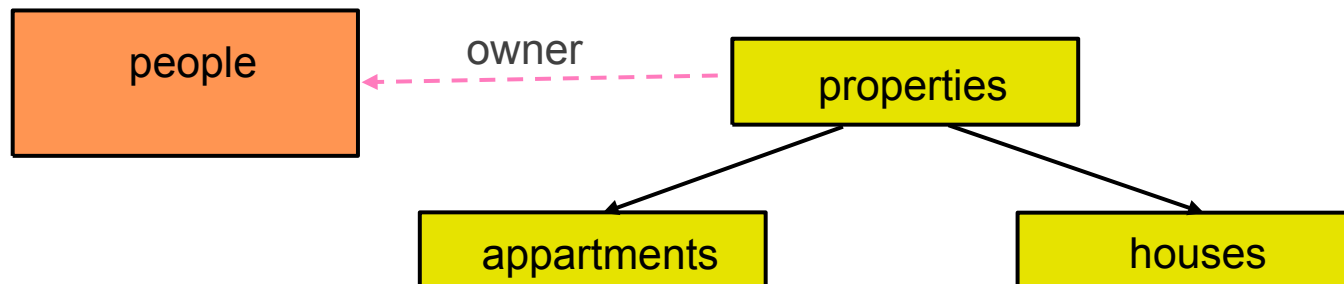

# Object Views

- Views have been extended to support
  - Typed views
  - View hierarchies
  - References on base tables can be mapped to references on views

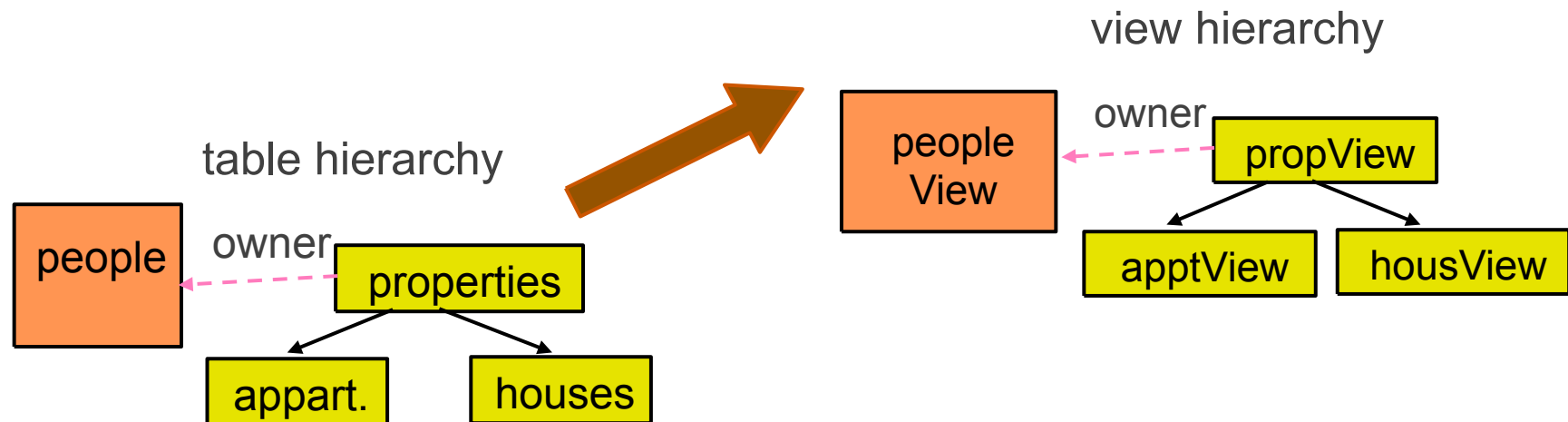
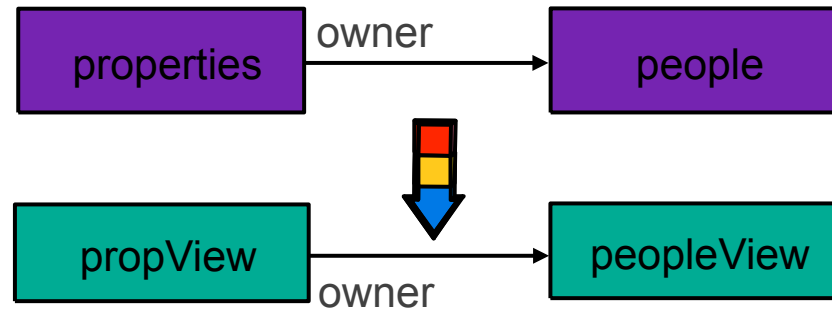

# Mapping Java Objects to Structured Types

- Support built into the DBMS
- Very flexible
  - DB understands internal structure of type
  - Based on SQL type system
  - Client applications written in other programming languages are supported
  - Can be used to define row types/typed tables
  - DB functions/methods can be implemented in other programming language
- Potential for better performance
- Requires conversion (Java  $\leftrightarrow$  SQL)

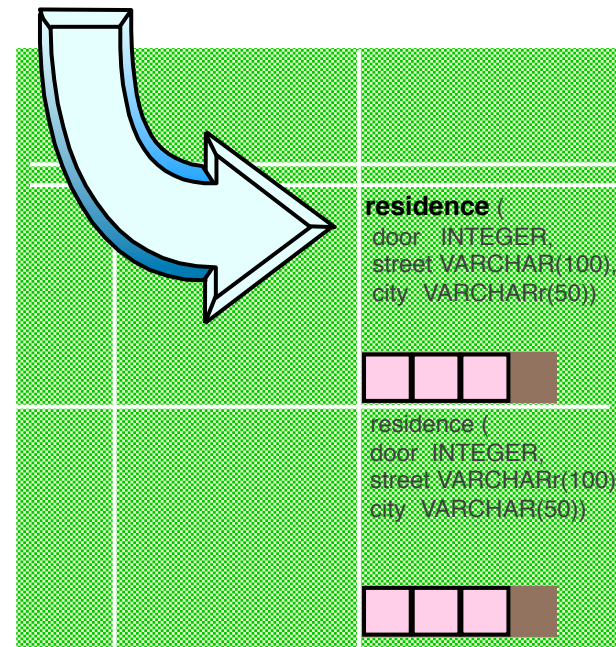

# SQLJ/JRT

---

- SQL Types using the Java™ Programming Language
- Use of Java classes to define SQL types
  - Can be mapped to structured types or "native" Java types (blobs)
  - Can be used to define columns in tables
  - Can be used to define SQL99 tables (structured types)
- Mapping of object state and behavior
  - Java methods become SQL99 methods on SQL type
  - Java methods can be invoked in SQL statements
- Automatic mapping to Java object on fetch and method invocation
  - Java Serialization
  - JDBC 2.0 SQLData interface



# Mapping Java Classes to SQL

- Described using extended CREATE TYPE syntax
  - DDL statement, or
  - Mapping description in the deployment descriptor
- Supported Mapping

Java	SQL
class	user-defined (structured) type
member variable	attribute
method	method
constructor	constructor method
static method	static method
static variable	static observer method

- SQL constructor methods
  - Have the same name as the type for which they are defined
  - Are invoked using the NEW operator (just like in Java)
- SQL does not know static member variables
  - Mapped to a static SQL method that returns the value of the static variable
  - No support for modifying the static variable

# Business Intelligence, Online Analytic Processing

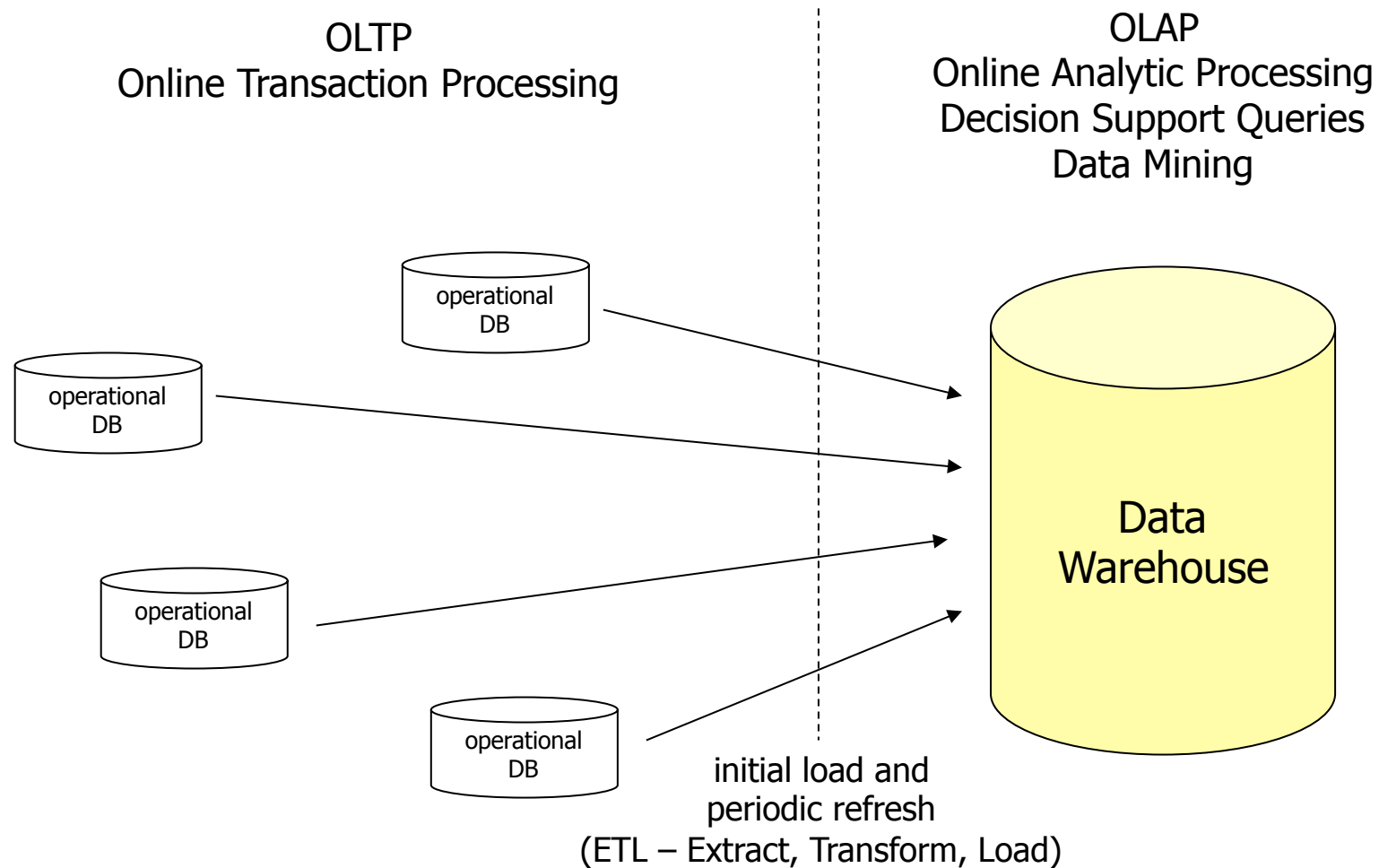



# OLAP Schema

- Typically uses a "STAR" structure
  - Dimension tables tend to be small
  - Fact table tends to be huge

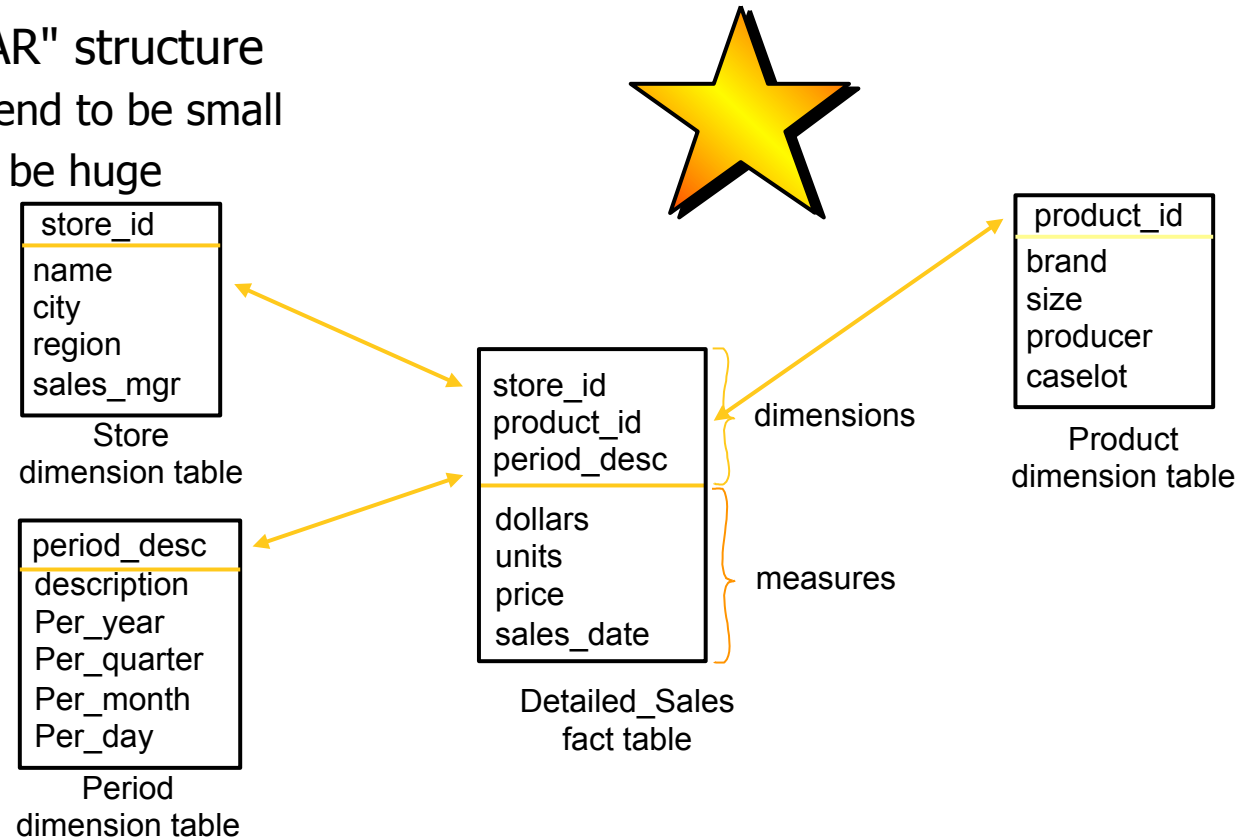

## CREATE VIEW Sales AS

```
(SELECT ds.*, YEAR (sales_date) AS year, MONTH (sales_date) AS month, DAY (sales_date) AS day
FROM (Detailed_Sales NATURAL JOIN Store NATURAL JOIN Product NATURAL JOIN Period) ds
```

# SQL99 OLAP SQL Extensions

- Extension to GROUP BY clause
- Produces "super aggregate" rows
- ROLLUP equivalent to "control breaks"
- CUBE equivalent to "cross tabulation"
- GROUPING SETS equivalent to multiple GROUP BYs
- Provides "data cube" collection capability
  - Often used with data visualization tool

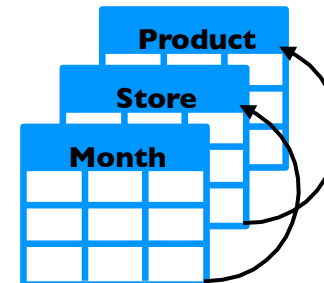
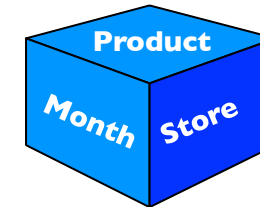

# CUBE

- Extends grouping semantics to produce multidimensional grouping and "subtotal" rows
  - Produces "regular" grouped rows
  - Produces same groupings reapplied down to grand total
  - Produces additional groupings on all variants of the CUBE clause

```
SELECT month, city, product_id, SUM(units)
FROM Sales
WHERE year = 1998
GROUP BY CUBE (month, city, product.id)
```

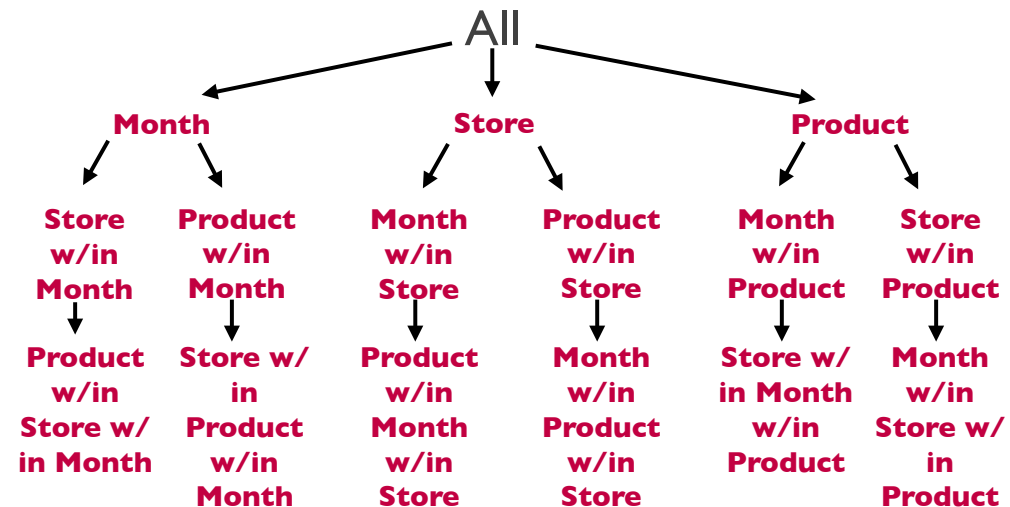

# Windows in SQL

- Set functions  
(aggregate functions)

```
SELECT dept, AVG(salary) AS avgsal
FROM Employees
GROUP BY dept
```

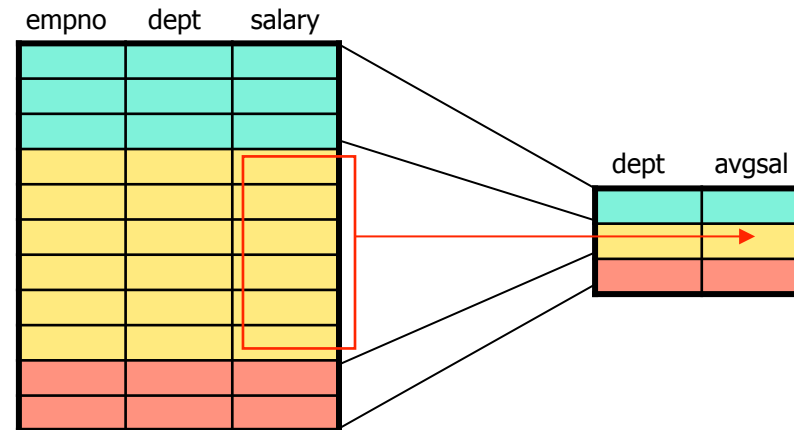

- Windowed Table Functions

```
SELECT dept, empno, salary,
       AVG(salary) OVER(
         PARTITION BY dept
         ORDER BY age
         ROWS
           BETWEEN 2 PRECEDING
            AND 2 FOLLOWING)
       AS c-avg
FROM Employees
```

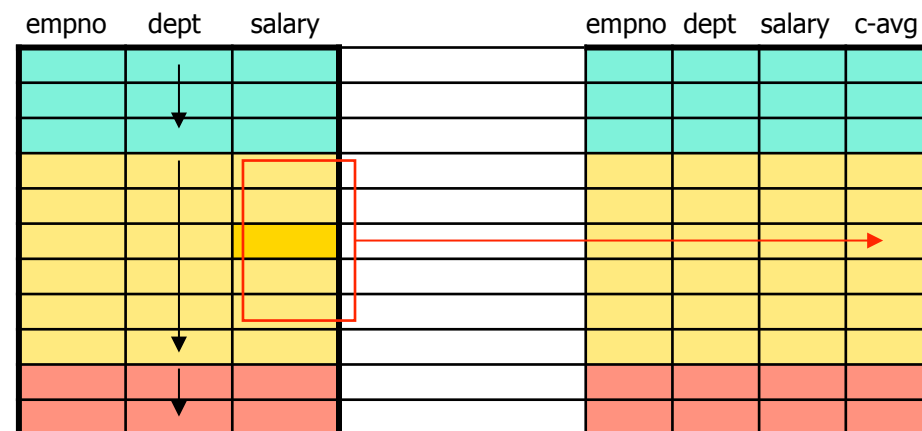

# XML Origin and Usages

---

- Defined by the WWW Consortium (W3C)
- Originally intended as a document markup language, not a database language
  - Documents have tags giving extra information about sections of the document
  - For example:
    - `<title> XML </title>`
    - `<slide> XML Origin and Usages </slide>`
- Derived from SGML (Standard Generalized Markup Language)
  - standard for document description
    - enables document interchange in publishing, office, engineering, ...
  - main idea: separate form from structure
- XML is simpler to use than SGML
  - roughly 20% complexity achieves 80% functionality

# Why is XML Important?

---

- Exchanging data among different systems or applications
  - neutral, flexible format
  - self-describing
- Wide range of support for processing XML
  - free/open source
  - major industry vendors
- Business reasons
  - increased agility, flexibility through easier adaptability of IT infrastructure
  - economic advantages
    - wide range of support
    - service-oriented architectures (SOA) promise better interoperability, software reuse
    - cost savings over proprietary electronic data interchange solutions
  - regulatory requirements and industry-specific initiatives
    - capture, maintain, monitor, store electronic transactions
    - "vertical" standards for data exchange

# Describing XML Data: XML Schema

---

- XML Schema is close to the general understanding of a (database) schema
- XML Schema supports
  - Typing of values
    - E.g. integer, string, etc
  - Constraints on min/max values
  - Typed references (for ID and IDREFS)
  - User defined types
  - Specified in XML syntax (unlike DTDs)
  - Integrated with namespaces
  - Many more features
    - List types, uniqueness and foreign key constraints, inheritance ..

# XQuery

---

- XQuery is a general purpose query language for XML data
- Standardized by the World Wide Web Consortium (W3C)
- Alpha version of XQuery engine available free from Microsoft
- XQuery is derived from
  - the **Quilt** (“Quilt” refers both to the origin of the language and to its use in “knitting ” together heterogeneous data sources) query language, which itself borrows from
    - **XPath**: a concise language for navigating in trees
    - **XML-QL**: a powerful language for generating new structures
    - **SQL**: a database language based on a series of keyword-clauses: SELECT - FROM – WHERE
    - **OQL**: a functional language in which many kinds of expressions can be nested with full generality



# XQuery: FLWOR Syntax

---

- XQuery is a functional language
  - Every query is an expression
  - Expressions can be nested with full generality:
    - XPath expressions
    - Element constructors
    - FLWR expressions
- Simple FLWOR expression in XQuery
  - Find all accounts with balance > 400, with each result enclosed in an <account-number> .. </account-number> tag

```
for   $x in /bank-2/account
let   $acctno := $x/@account-number
where $x/balance > 400
return <account-number> {$acctno} </account-number>
```

# SQL and XML?!

---

- Two major perspectives
  - Flexible exchange of relational data using XML
    - publish relational as XML
    - decompose or "shred" XML into relational
  - Reliable XML data management
    - manage, search, maintain, update, ...
    - integrate with relational data
- Native-XML databases? No significant customer interest!
  - reluctance to introduce new DBMS environment
  - limited integration with relational DBMS products
  - lack of maturity (scalable, reliable, highly available, ...)
  - skill revolution (not evolution) required

Remember OO-DBMS?

# SQL/XML Big Picture

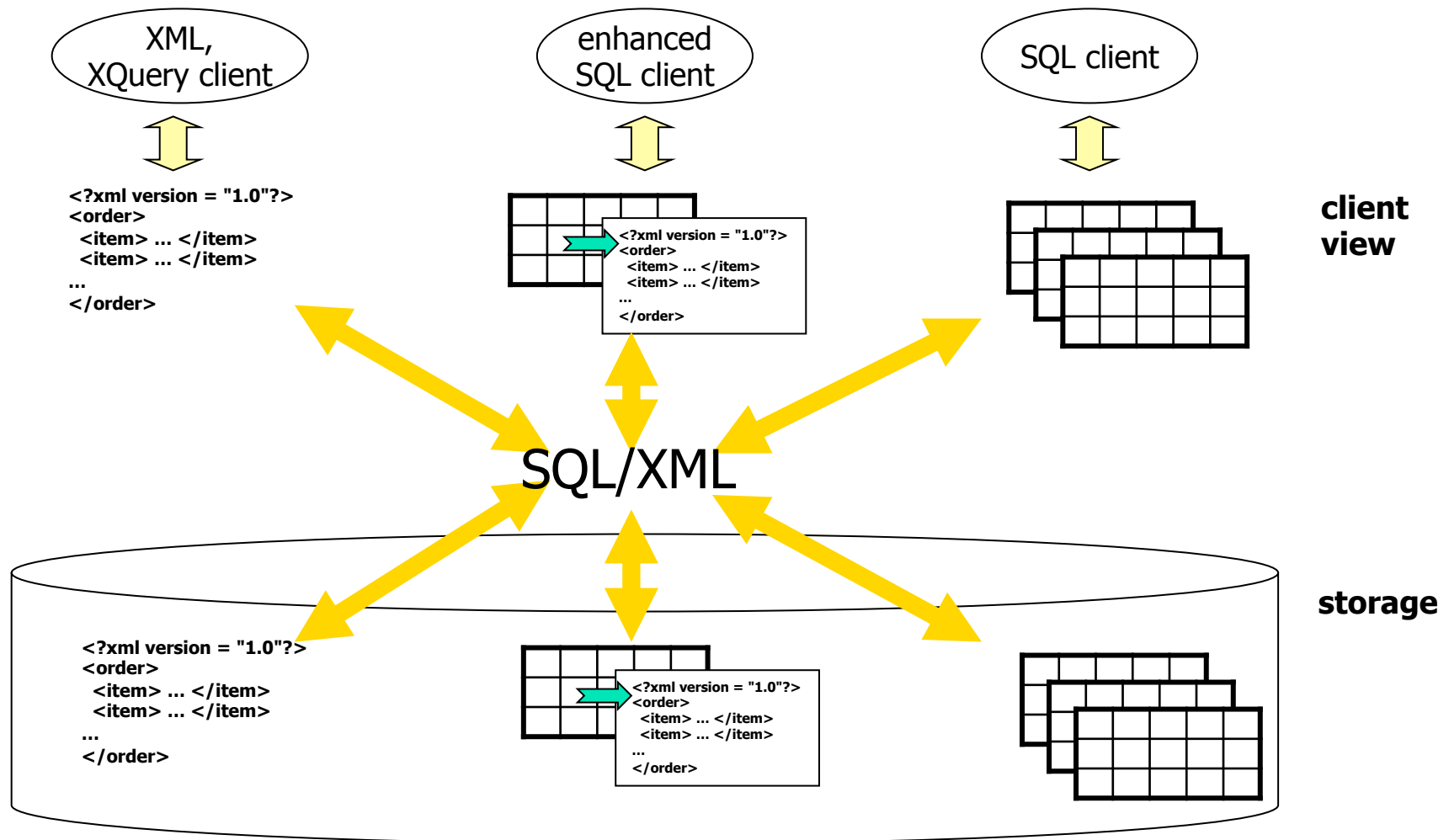

# SQL:2003 Parts and Packages

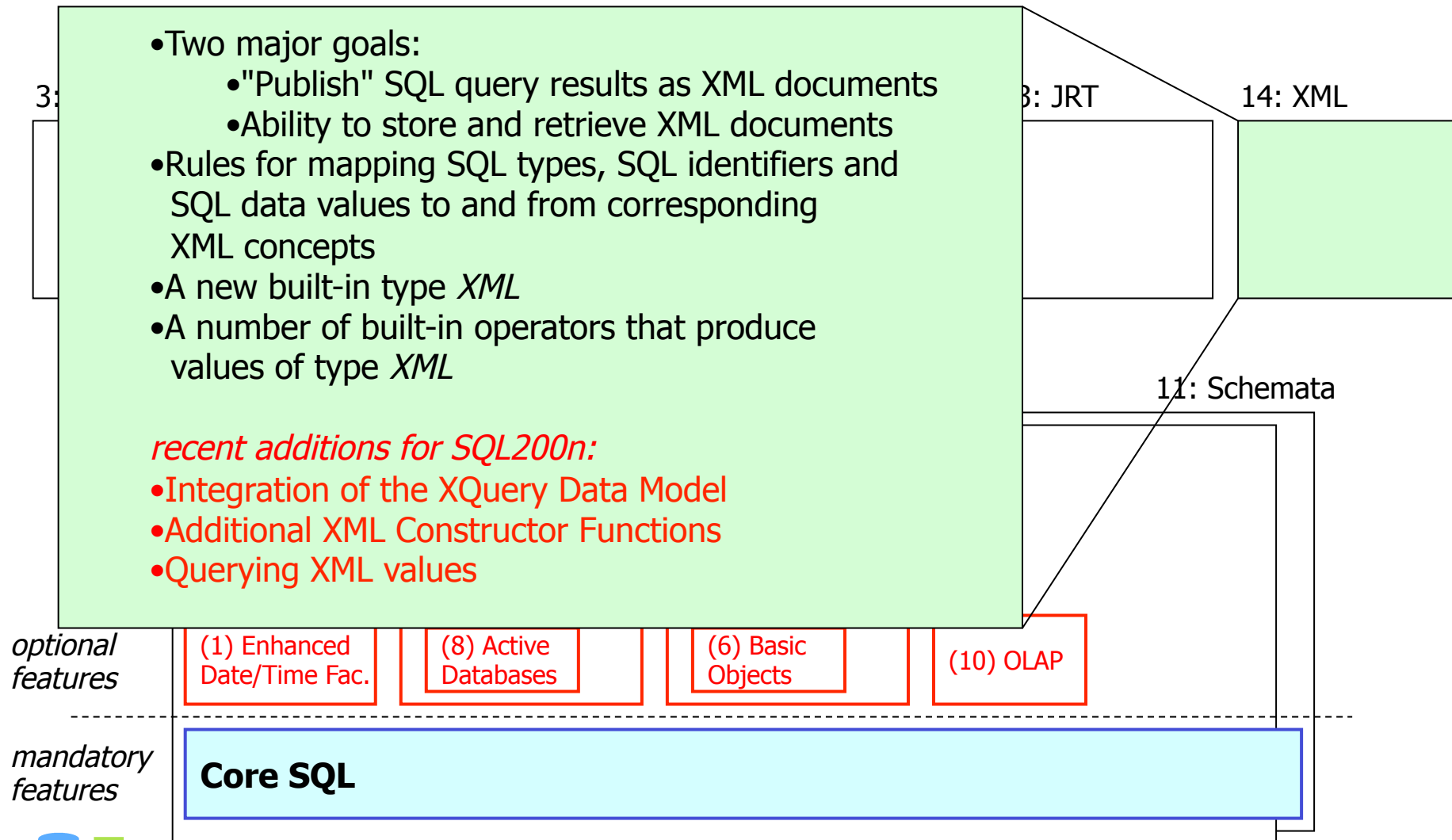

# XML Data Type

```
CREATE TABLE employee
  ( id CHAR(6),
    lastname VARCHAR (30),
    ...,
    resume XML
  )
```

ID	LASTNAME	...	RESUME
940401	Long	...	<pre>&lt;?xml version="1.0"?&gt; &lt;resume xmlns="http://www.res.com/resume"&gt;   &lt;name&gt; ... &lt;/name&gt;   &lt;address&gt; ... &lt;/address&gt;   ... &lt;/resume&gt;</pre>
862233	Nicks	...	null
766500	Banner	...	<pre>&lt;resume   ref="http://www.banner.com/resume.html"/&gt;</pre>

# XML Publishing Functions - *Example*

```
SELECT  e.id,  
        XMLELEMENT (NAME "Emp",  
                    e.fname || ' ' || e.lname)  
        AS "result"  
FROM    employees e  
WHERE   ... ;
```

==>

ID	result
1001	<Emp>John Smith</Emp>
1006	<Emp>Mary Martin</Emp>

# XMLQUERY

- Evaluates an XQuery or XPath expression
  - Provided as a character string literal
- Example

```
SELECT XMLQUERY( 'for $e in $dept[@count > 3]/emp
                  where $e/hire > 2004-12-31 return $e/name'
                PASSING BY REF deptDoc AS "dept"
                RETURNING SEQUENCE) AS "Name_elements"
FROM XMLDept
```

=>

Name_elements
<name>Miller</name>
<name>Smith</name>
<name>Johnson</name>
<name>Martin</name>