

Chapter 8 - Web Service Composition and E-Business Collaboration



Motivation

- Complex web services
 - Need to interact with business partners through web services
 - May combine/utilize existing web services
 - Web services composition
 - Ability to create new web services out of existing (web service) components
 - Requirements similar to BPM, Workflow Management
 - separate function from composition logic, ...
 - Composition can be iterated
 - Composition result is again a web service
 - Can be used as a building block for further composition steps
- ⇒ Middleware for web service composition



Web Services Composition Middleware

- Main elements
 - composition model and language
 - composed WS is expressed by a composition schema (script)
 - development environment
 - graphical end user tools
 - run-time environment
 - composition "engine"
- Composition vs. coordination middleware
 - composition: focus is on implementation of operations in a web service
 - internal, private
 - for automation of the execution of a composite web service
 - coordination: focus is on conversation protocols
 - public, standardized protocols
 - external coordination for verifying compliance



Web Services vs. WFMS

- Limitations of conventional composition middleware (e.g., WFMS)
 - Significant effort to integrate existing applications
 - application-specific adapters, wrappers
 - no standard model for component description, interoperability
 - Limited success of composition model standardization
 - WfMC standard is not widely implemented
- Opportunities for Web Services
 - Web Services seem to be adequate components
 - well-defined interfaces, described using WSDL
 - standardized invocation (SOAP)
 - Significant efforts in standardizing WS composition languages
 - Reuse of existing WS "infrastructure" (directory, service selection, ...)
 - WS composition tools are less expensive to develop



Business Processes and Web Services

- Business Process Execution Language for Web Services (BPEL4WS)
 - XML-based language for specifying business process behavior based on web services
 - Describe business processes that both provide and consume web services
 - Steps (activities)
 - Implemented as an interaction with a web service
 - Information flow into/out of the process
 - Externalized as web service
- Complemented by
 - WS Coordination specification
 - Allows to web services involved in a process to share information that "links" them together
 - Shared coordination context
 - WS AtomicTransaction, WS BusinessActivity specifications
 - Allows to monitor the success/failure of each coordinated activity
 - Reliably cancel the business process, involves compensating activities
- Standardization through OASIS



BPEL4WS

- BPEL can support specification of both, composition schemas and coordination protocols
 - can be used in both composition and coordination middleware
- Two types of processes
 - executable process (-> composition)
 - defines implementation logic for a composite web service
 - portable between BPEL-conformant environments
 - abstract process (-> coordination)
 - service-centric perspective on coordination protocols
 - describe message exchange between partners
- Business process defines
 - potential execution order of operations (web services)
 - data shared between the web services
 - correlation information
 - partners involved in business process and interfaces they need to implement
 - joint exception handling for collection of web services



BPEL Component Model

- Components are web services described using WSDL
 - abstract WSDL interfaces are referenced in BPEL scripts
 - no reference to bindings, endpoints, or services
- Basic activities in BPEL represent components, correspond to WSDL operations
 - Invoke
 - Issue an asynchronous request, or
 - Synchronously invoke a request/reply operation of a web service provided by a partner
 - Receive
 - Wait for a message to be received from a partner
 - Specifies partner from which message is to be received, as well as
 - The port and operation provided by the process
 - Used by the partner to pass the message
 - Reply
 - Synchronous response to a request corresponding to a receive activity
 - Combination of Receive/Reply corresponds to request-response operation in WSDL



Example

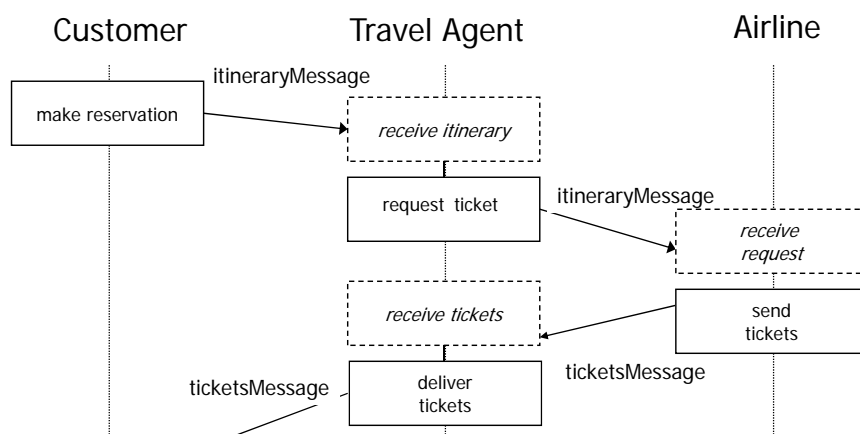

Service Selection: Partner Links

- Partner link (BPEL process definition)
 - identifies the web services mutually used by the partner or process
 - e.g., agent process interacts with customer, airline
 - references a partner link type
 - defines role taken by the process itself (myRole) and role that has to be accepted by the partner (partnerRole)
- Partner link names are used in all service interactions to identify partners
 - see activities for invoking/providing services

- Partner link type (WSDL extension) defines
 - roles played by partners in a conversational relationship
 - web service interfaces that need to be implemented to assume a role
- Assignment of endpoints for partners
 - at deployment time
 - dynamically at run time

Partner link type definition

```

1 <process name="ticketOrder">
2 <partnerLinks>
3 <partnerLink name="customer"
4   partnerLinkType="agentLink"
5   myRole="agentService"/>
6 <partnerLink name="airline"
7   partnerLinkType="buyerLink"
8   myRole="ticketRequester"
9   partnerRole="ticketService"/>
10 </partnerLinks>
    
```

```

1 <partnerLinkType name="buyerLink">
2 <role name="ticketRequester">
3 <portType name="itineraryPT"/>
4 </role>
5 <role name="ticketService">
6 <portType name="ticketOrderPT"/>
7 </role>
8 </partnerLinkType>
    
```



BPEL Activities – Example

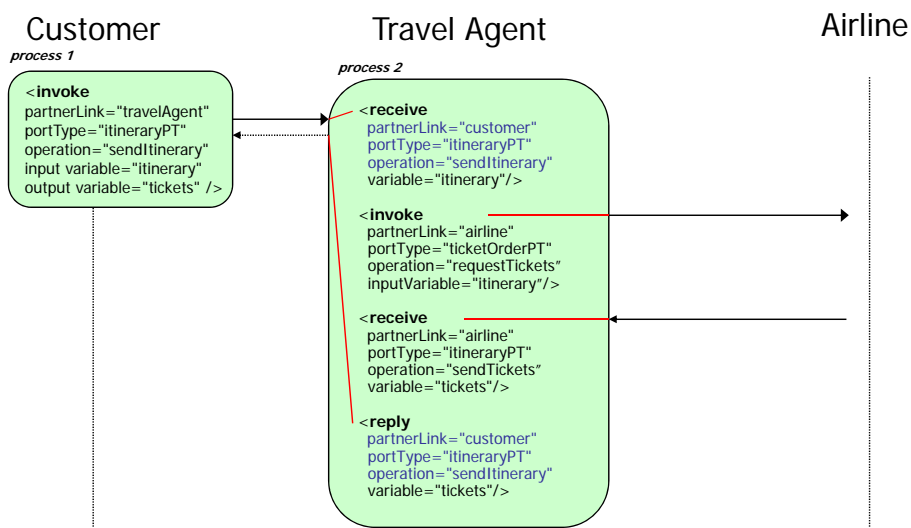

Orchestration Model - Structured Activities

- Sequence
 - Enclosed activities are carried out in listed order
- If-else (i.e., switch)
 - Selects one of several activities based on selection criteria
- Repetitive Activities
 - While, RepeatUntil,
 - repeatedly carry out enclosed activities while/until specified condition is true
 - ForEach
 - serial: enclosed activity (scope) is carried out repeatedly, based on counter, optional completion condition
 - parallel: (effective copies of) enclosed activity (scope) executed n+1 times in parallel, based on start/end counter values
- Pick
 - Specifies a set of activities with associated events (e.g., receipt of message)
 - messages can be received from the same or different partners
 - activity is completed when one of the events occurs



Structured Activities (cont.)

- Flow activity: defines sets of activities plus (optional) control flow
 - all activities can (potentially) execute in parallel
 - flow activity completes when all directly nested concurrent activities complete
 - implicit fork/join behavior
 - activities can be "wired together" via control links
 - link has one source activity, and one target activity
 - transition conditions
 - evaluated after source activity completes
 - determines the link status to be either true or false
 - links status also set to false, if source activity is determined not to be executed (e.g., if-else)
 - join conditions
 - can refer to status of incoming links of a target activity (e.g., AND, OR)
 - are evaluated only after the status of all incoming links is known
 - false join condition results in a join failure
 - dead path elimination
 - failure may be suppressed, status "false" is propagated to outgoing links

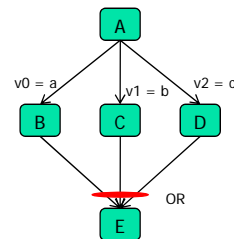

Process life-cycle

- Start activities
 - receive, pick – createInstance attribute
 - creates a new process instance, if it doesn't exist already
 - Example:

```
<receive partner="customer",
  portType="itineraryPT",
  operation="sendItinerary",
  variable="itinerary"
  createInstance="yes" />
```
 - each process must have at least one start activity as an initial activity
- Process termination
 - process-level activity completes successfully
 - fault "arrives" at the process level (handled or not)
 - terminate activity is invoked



Data Types and Data Transfer

- **Variables** can be used to define data containers
 - WSDL messages received from or sent to partners
 - Messages that are persisted by the process
 - XML data defining the process state
- Constitute the "business context" of the process
- Access to variables can be serialized to some extent

```
11 <variables>
12   <variable name="itinerary" messageType="itineraryMessage"/>
13   <variable name="tickets" messageType="ticketsMessage"/>
14 </variables>
```

- Variable assignment
 - Receiving a message (or a reply of an invoke activity) implicitly assigns value
 - Alternative: **assign** activity (another simple activity)
 - Copies fields from containers into other containers



Correlation

- Message needs to be delivered not only to the correct port, but to the correct instance of the business process providing the port
 - conversation routing
- Correlation Set
 - one or more properties used for correlating messages
 - example
 - ```
<correlationSets>
 <correlationSet name="Booking"
 properties="orderNumber"/>
 ...
</correlationSets>
```
    - correlation properties are like "late-bound constants"
      - binding happens through specially marked message send/receive activities
      - value must not change after the binding happens
  - Often, more than one correlation set is used for an entire process
    - example: orderNumber -> invoiceNumber
    - correlated message exchanges may nest, overlap
    - same message may carry multiple correlation sets



## Properties

- Property
  - Globally defined types
  - Primarily used to correlate a message with a specific process instance
    - E.g., order number
    - Usually included in the message
    - Often the same property is used in different messages
  - Can be defined in BPEL as a separate entity:  
9 

```
<property name="orderNumber" type="xsd:int"/>
```
- Property alias
  - Allows to point to a dedicated field of the message that represents the property
    - Usually different for each message type
    - Can be used in expression and assignments to easily use properties
  - 10 

```
<propertyAlias propertyName="orderNumber"
11 messageType="ticketsMessage"
12 part="orderInfo"
13 query="/orderID"/>
```





## Scope

- Defines the behavior context of an activity (primary activity)
  - simple or structured (group of activities)
- Can provide the following for a (regular) activity
  - (Local) data variables
  - Correlation Sets
  - Event handler(s)
  - Fault handler(s)
  - Termination handler
  - Compensation handler
    - Scope acts as a compensation sphere
- Scopes can be arbitrarily nested



## Fault Handlers and Termination Handler

- **Fault handlers** catch and deal with faults occurring in **active** scope
  - Can catch internal faults (throw activity), WS fault messages
  - All active work in the scope is stopped!
    - Results in invocation of termination handlers for active enclosed scopes
  - After fault handler completes successfully, processing continues outside the scope
    - Processing of the scope is still considered to have ended abnormally
- **Termination handler** allows to define scope-specific termination behavior
  - Invoked if an active scope needs to be terminated
    - Example: perform cleanup work, notify business partner, cancel activity
  - For nested scope: TH for inner scope is invoked before the TH of the outer



## Compensation Handlers

- **Compensation handlers** reverse the work of a **successfully completed** scope
  - Compensation handler is "installed" after successful completion of the scope
  - Can be defined for each scope
  - Compensation activity can be any activity
  - Compensation handlers live in a snapshot world
    - When invoked, they see a snapshot of the variables at scope completion time
    - Cannot update "live" data variables
    - Can only affect external entities
    - Input/output parameters for compensation handler are future direction
- **Compensate** activity
  - Invokes compensation handler for named scope
  - Can be invoked only from the fault handler or compensation handler of the immediately enclosing scope



## Fault-Termination-Compensation - Example

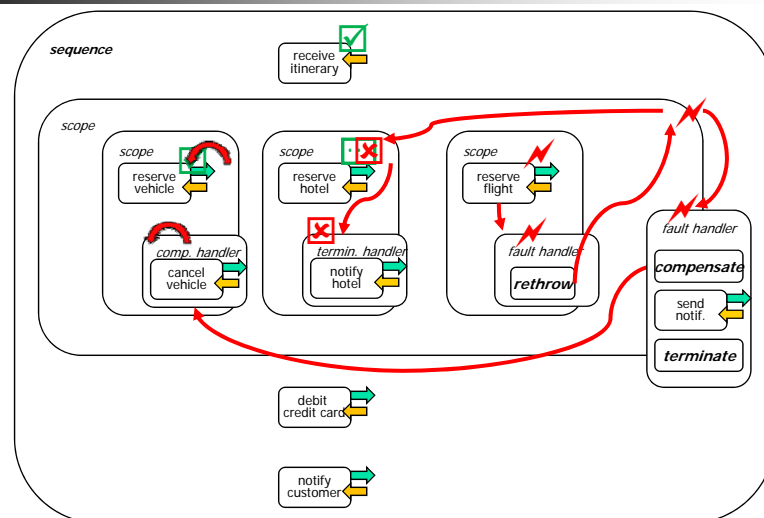

## Default Compensation and Fault Handlers

- Default compensation handler
  - Invokes compensation handlers of immediately enclosed scopes in the **reverse order of the completion** of the scopes
  - Is used if a (enclosing) scope does not explicitly define a compensation handler
  - Can also be invoked explicitly
    - Useful if comp. action = "compensate enclosed scope in reverse order" + "additional activities"
- Default fault handler
  - Invokes compensation handlers of immediately enclosed scopes in the reverse order of the completion of the scopes
  - Rethrows the exception



## BPEL – Abstract Processes

- Abstract Process = Role-specific view of a protocol
  - only public information
  - no private, implementation-specific aspects
    - branching conditions, activity realization, ...
  - not executable
  - can be used by a **conversation controller** to ensure **business protocol compliance**
- Properties of BPEL abstract processes
  - handle only protocol-relevant data
    - message properties
  - variables
    - do not need to be fully initialized
    - variables for inbound or outbound messages may be omitted from invoke, receive, reply, if the intent is to just constrain the sequence of activities
  - opaque assignments
    - can correspond to creating a unique value for correlation properties
    - hide private behavior for providing the values



## Implementing Business Protocols

- Suggested path
  - protocol specification as a starting point
  - derive role-specific views of the protocol
    - includes all the message exchanges that involve a certain role
  - define **abstract process** for role-specific view
    - model interactions using receive, invoke, reply
    - represent additional public information, such as branching situations, parallelism
  - turn abstract process into an **executable process** to implement it

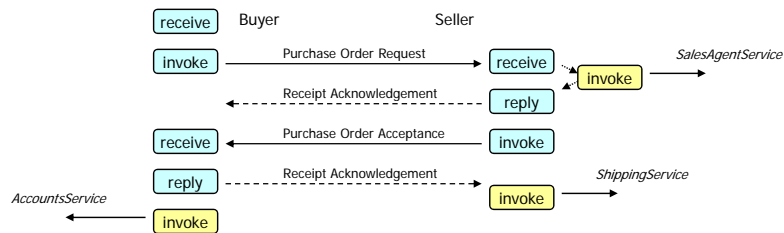

© Prof. Dr.-Ing. Stefan Deßloch

23

Enterprise Information Systems

## RosettaNet

- Goal: Develop standard e-commerce interfaces to align the processes between IT supply chain partners
  - consortium founded in 1998
  - "vertical" coordination protocols
  - more than 3000 documented production implementations by 2004
- Main standardization areas
  - (Public) Business processes
    - coordination protocols for trading partners
    - Partner Interface Processes (PIPs)
      - business documents, vocabulary, choreography of message exchanges
  - Data format
    - establishment of a common vocabulary
      - business directory
      - technical dictionary
  - Message services
    - RosettaNet Implementation Framework
      - reliable, secure execution of the protocol specifications
      - transfer, routing, packaging of encrypted and authenticated messages between business partners



© Prof. Dr.-Ing. Stefan Deßloch

24

Enterprise Information Systems

## RosettaNet Trading Partner Implementation

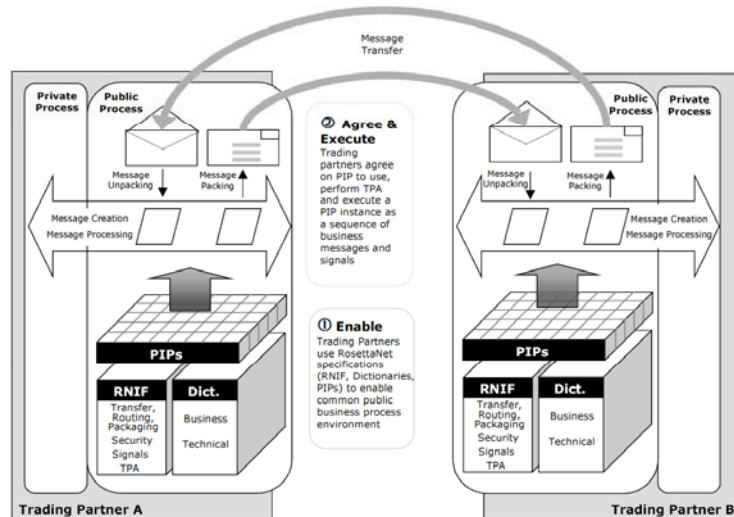

[source: RosettaNet Implementation Framework Core Specification]



© Prof. Dr.-Ing. Stefan Deßloch

25

Enterprise Information Systems

## PIP Definitions

- Standardized PIP definitions are arranged into clusters, further broken down into segments
- Clusters:
  1. RosettaNet Support
    - administrative functionality
  2. Partner Product and Service Review
    - collect, maintain, distribute product or service information
      - account setup, product info subscription, ...
  3. Product Information
    - distribute, update product information
      - query technical product info, ...
  4. Order Management
    - request quote, request purchase order, query order status, ...
  5. Inventory Management
    - distribute inventory report, ...
  6. Marketing Information Management
    - exchange of marketing information
  7. Service and Support
    - request warranty claim, ...
  8. Manufacturing
    - "virtual manufacturing"
      - notify of manufacturing work order, ...



© Prof. Dr.-Ing. Stefan Deßloch

26

Enterprise Information Systems

## Partner Interface Process (PIP) Specifications

- Describes how to implement a collaborative coordination protocol
  - technical dictionary describes components that are exchanged
  - message guideline document
    - business actions, business signals (ack receipt of action message)
- Major PIP specification sections
  - Business Operational View (aka Action Layer)
    - flow of business interactions, based on
      - partner roles
      - partner role interactions
  - Functional Service View (aka Transaction Layer)
    - derived from the business operational view
    - business transactions between entities in the form of message exchanges
      - coordination protocols
      - message control information
        - time limits for acknowledgements
        - security requirements
  - Implementation Framework View (aka Service Layer)
    - based on functional service and business operational views
    - defines communication protocol and message format requirements
      - e.g., SSL, encryption, XML DTDs for messages, ...



© Prof. Dr.-Ing. Stefan Deßloch

27

Enterprise Information Systems

## Business Operational View - Example

- Business Process Diagram for PIP3A4: Request Purchase Order

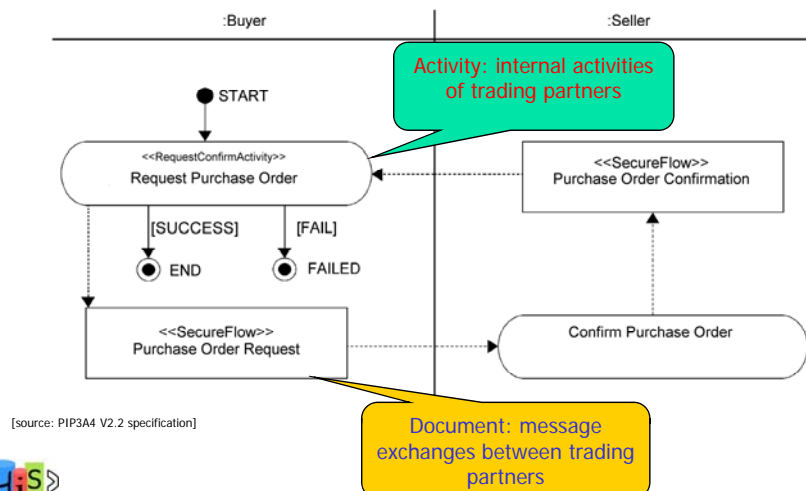

© Prof. Dr.-Ing. Stefan Deßloch

28

Enterprise Information Systems

## Functional Service View – Example

- Business Transaction Dialog Specification for PIP3A4: Request Purchase Order

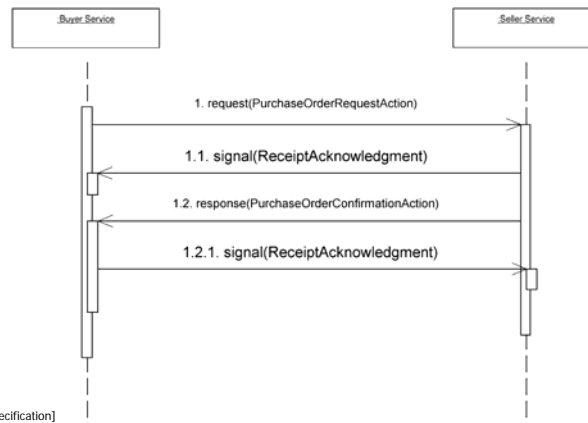

[source: PIP3A4 V2.2 specification]



© Prof. Dr.-Ing. Stefan Deßloch

29

Enterprise Information Systems

## RosettaNet Implementation Framework

- Defines
  - Business Message
    - packaging payload (incl. attachments), headers, ...
    - uses MIME, S/MIME
  - Protocol Stack
    - transport-independent
    - reliable messaging
      - support for HTTP, SMTP, ...
  - Security Mechanism
    - based on encryption, digital signatures
    - supports authentication, authorization, encryption, non-repudiation
- Designed before the time of SOAP
  - May likely be replaced by SOAP-based web service infrastructure in the future

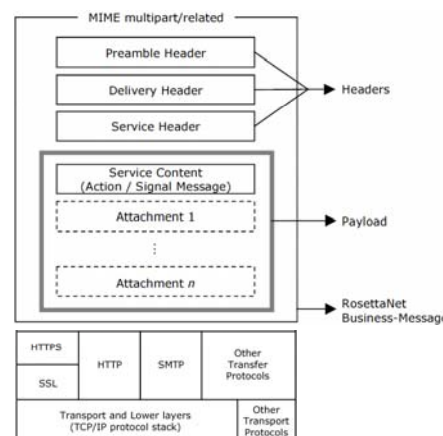

[source: RosettaNet Implementation Framework Core Specification]



© Prof. Dr.-Ing. Stefan Deßloch

30

Enterprise Information Systems

## Implementing RosettaNet PIPs

- Involves mapping PIP to WSDL, BPEL
  - types in message definitions -> types in WSDL
    - DTDs to XML Schema
  - message definitions -> WSDL message definitions
  - PIP actions -> operations in WSDL
  - PIP partner roles -> BPEL partners
  - PIP choreography: follow the "suggested path" on previous chart
- Additional aspects
  - realize time-outs, etc. using BPEL events and fault handlers
  - additional requirements regarding security need to be resolved
    - WS-Security support, not integrated in BPEL



## ebXML

- Supported by UN/CEFACT, OASIS
- Vision
  - single global electronic marketplace
  - based on exchange of XML messages
- ebXML architecture covers:
  - definition of business processes and their associated messages and content
  - registry and discovery of business process sequences with related message exchanges
  - definition of company profiles
  - definition of trading partner agreements
  - uniform message transport layer
- ebXML advantages
  - goes beyond generic protocols and specifications
    - e.g., ebXML registry is much more detailed than UDDI
  - captures the logic behind e-commerce exchanges
    - e.g., business arrangements
  - specifies how e-commerce exchanges should be specified, documented, conducted





## Collaboration with ebXML

- Example

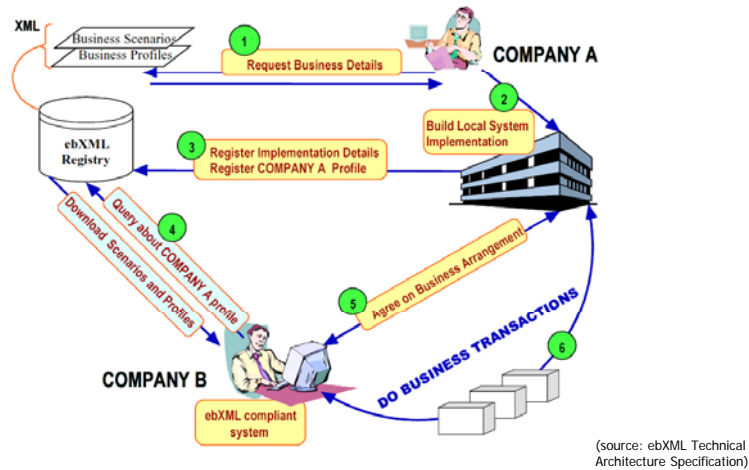

© Prof. Dr.-Ing. Stefan Deßloch

33

Enterprise Information Systems

## Technical Architecture

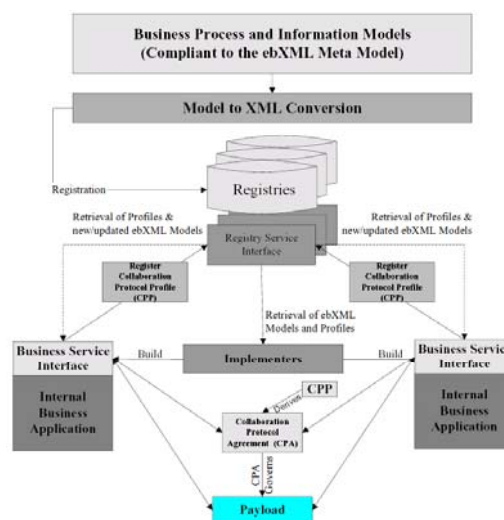

© Prof. Dr.-Ing. Stefan Deßloch

34

Enterprise Information Systems

## How Do These Standards Relate?

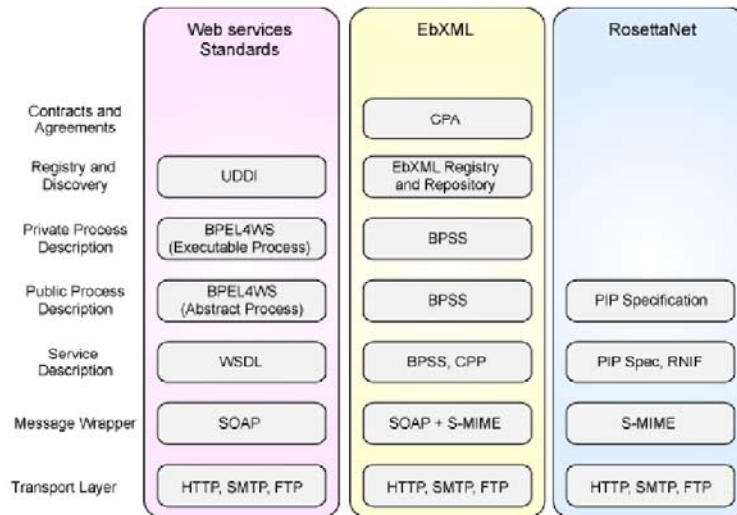

© Prof. Dr.-Ing. Stefan Deßloch

35

Enterprise Information Systems

## Summary

- Web service composition
  - means to implement web service by reusing/combining existing services
  - can be supported by WS composition middleware
    - borrowing concepts from WFMS
- BPEL
  - de-facto and de-jure (OASIS) web service composition standard
  - allows definition of **composition** and **coordination** aspects
    - abstract vs. executable processes
  - main concepts
    - basic activities for web service operations
    - structured activities for defining service composition, control flow
    - blackboard approach for data flow based on variables
    - service selection based on partner link types, partner links, endpoints
    - elaborate model for transactions and exception handling
      - fault handler, termination handler, compensation handler
- More BPEL extensions are on the way
  - people WF (BPEL4People, WS-HumanTask), Java/SQL snippets (BPELJ, BPEL/SQL)



© Prof. Dr.-Ing. Stefan Deßloch

36

Enterprise Information Systems